

SANCTUARY CANOPY

— VERANDAS & CARPORTS —

INSTRUCTION GUIDE

PLEASE READ THESE INSTRUCTIONS FULLY
BEFORE COMMENCING ANY WORK

Rev J
January 2023

FOR VIDEO INSTRUCTIONS & MORE INFO PLEASE VISIT
www.cabp.co.uk

1. Add gasket to wall plate

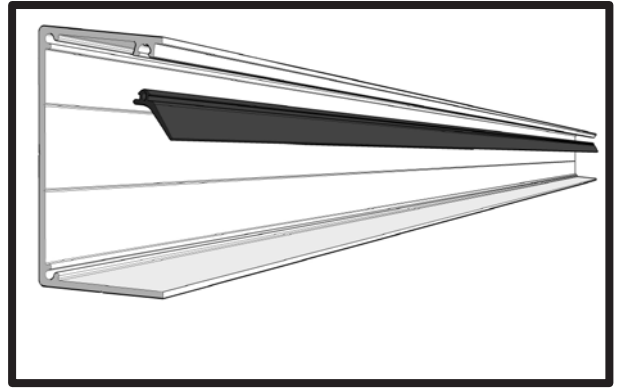

2. Drill holes in wall plate along the two rib lines

- The first pair of holes should be 25mm from the edge and then spaced every 525mm along the length. The last pair should be 25mm from the far edge. The hole centers can be adjusted to cater for obstructions on the retaining wall.
- An 8mm diameter metal drill bit should be used for this.

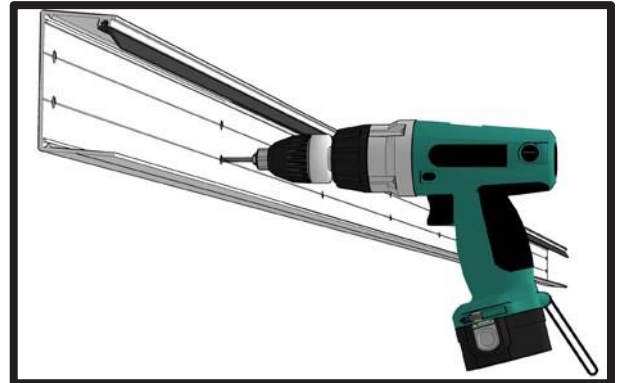

EXAMPLE DIMENSIONS FOR THE 4250mm 4 PANEL OPTION:

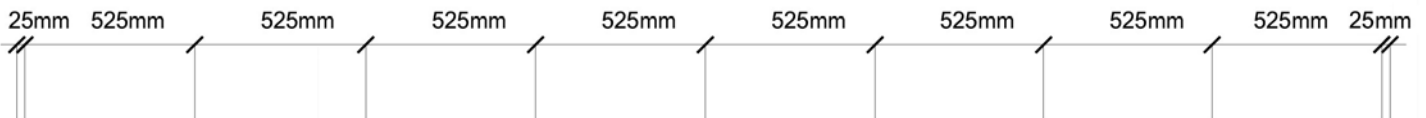

PLEASE NOTE: THE SANCTUARY WALL PLATES AND GUTTERS ARE CUT TO SIZES TO SUIT THE MULTIWALL SHEETS. WHEN USING SOLID SHEETS, YOU WILL NEED TO CUT THE WALL PLATE AND GUTTER DOWN TO SUIT. FOR MORE INFO ON SOLID SHEETING REFER TO POINT 35.

3. Offer the wall plate up to the host wall, mark the holes, remove wall plate

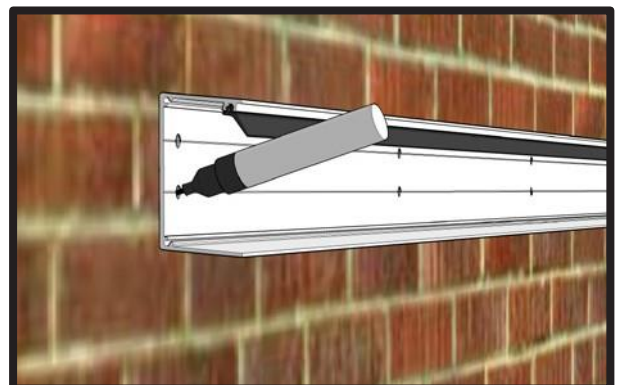

4. Drill an 8mm diameter hole for the fixings of the wall plate using masonry drill bit to a suitable depth (110mm).



5. Offer wall plate to the wall, fasten the wall plate using the through fixing frame anchors.

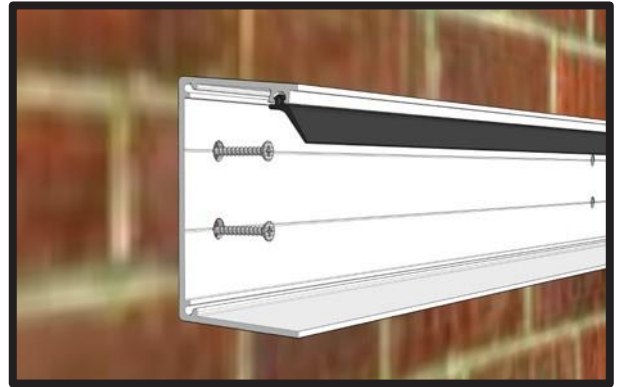

6. Run a bead of silicone along the top of wall plate against the wall to seal.

- If the wall is uneven then a secondary flashing such as chased in lead or flashband may be required.

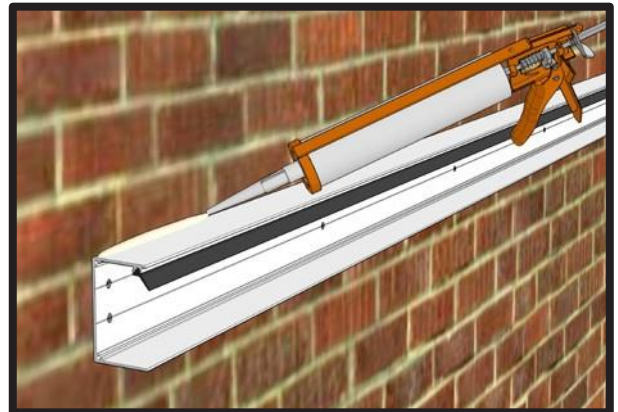

7. Position the location of the Post Connector Bracket to your sound concrete floor (if the floor is not suitable then it must be recast to be suitable) and mark the center holes.

- Posts should never be more than 2.75m apart, or 0.25m from the ends of the gutter / beam.
- Ensure that the holes run parallel to the host wall, this ensures the gutter beam will be parallel

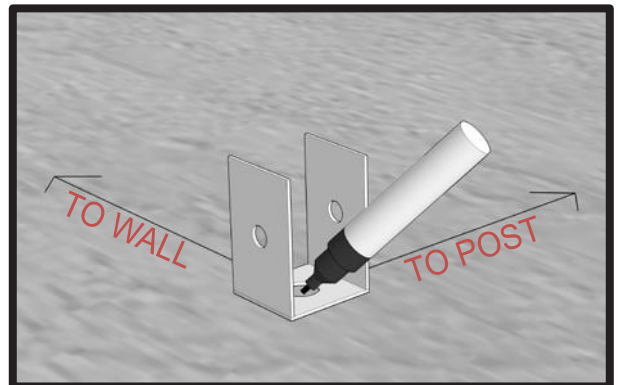

8. Drill the holes marked using a 12mm diameter masonry drill to depth of 90mm ensuring any debris is removed

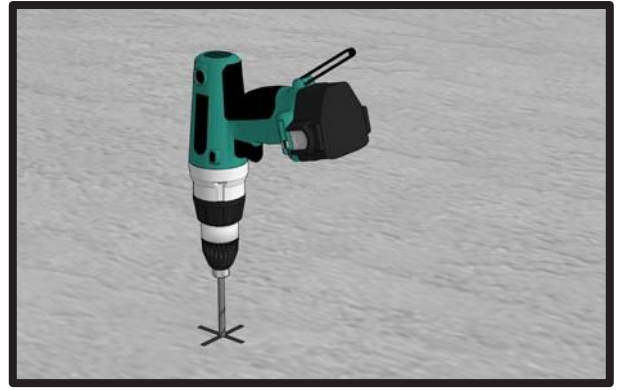

9. Reposition the post connector bracket and fasten to the floor using the shield anchor.

- Ensure the vertical flanges are at right angles to the wall so that when the bolt connecting it to the post is inserted these are inserted parallel.
- Ensure the connectors are in straight line ready for the posts. The Base hole on the connector is oversized to allow for some minor adjustments to ensure these are in line. Used for this.

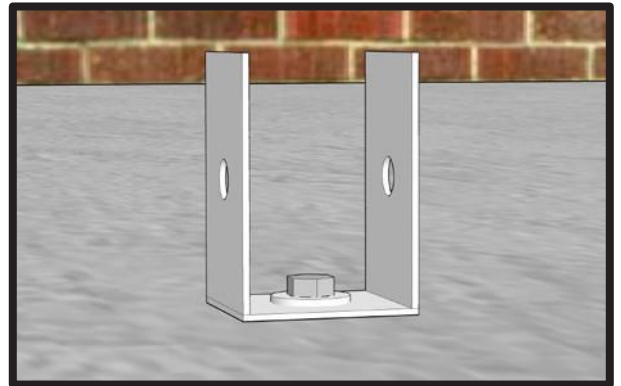

10. Drill a 12mm diameter hole in each of the 60mm x 60mm posts 40mm from the end and central on the face. Secondly, drill 2 holes on the adjacent sides to allow for drainage approximately 10mm from the end of the post

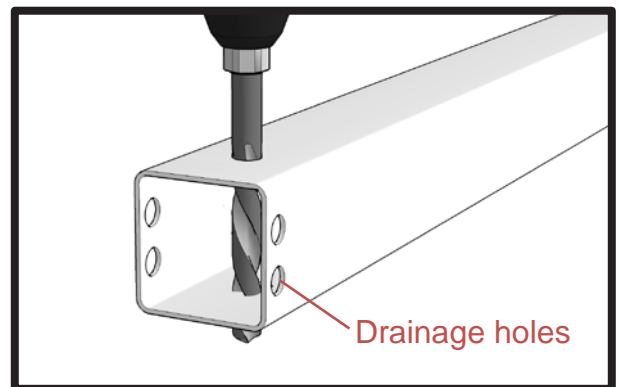

11. Locate each post over the connector bracket and secure through with the M12 x 70mm stainless bolt.

- Make sure that the drainage holes are not obstructed on the inside and sit clear of the post connector

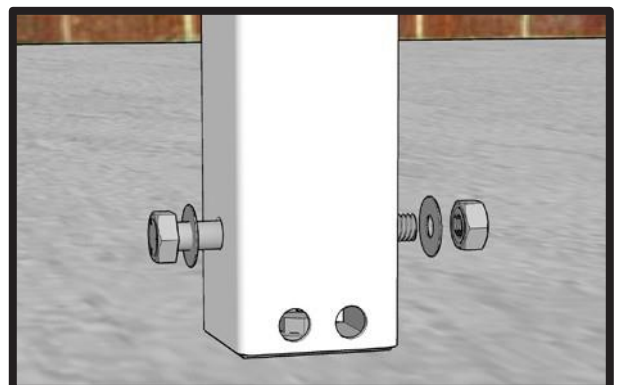

12. Decide on which post / posts are going to be use as downpipe and mark the location on the inside of the gutter with two straight lines representing the edges of the posts

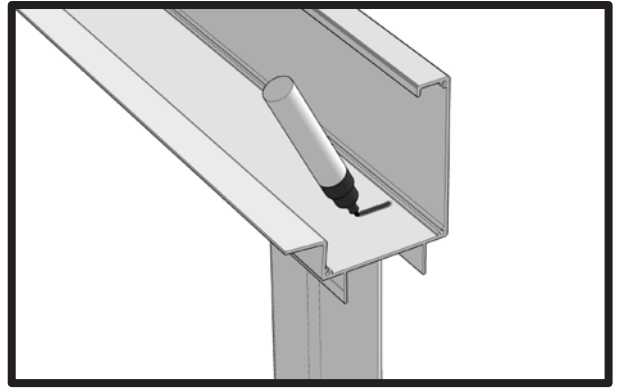

13. Within these lines drill several holes so the water can escape down the inside of the post.

- Use the same 12mm diameter as used for the post then you should get 9 holes, if using a smaller diameter drill more holes would need to be drilled.
- Drilling the holes instead of using a hole cutter will help ensure no large debris enters the post to cause a blockage.

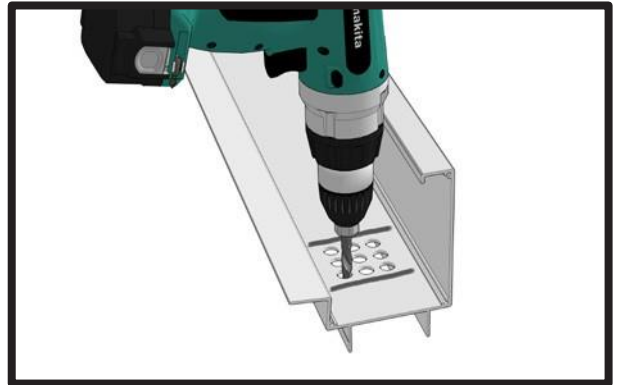

14. Screw the Gutter Beam Endplates onto the section, sealing on the inside using silicone sealant.

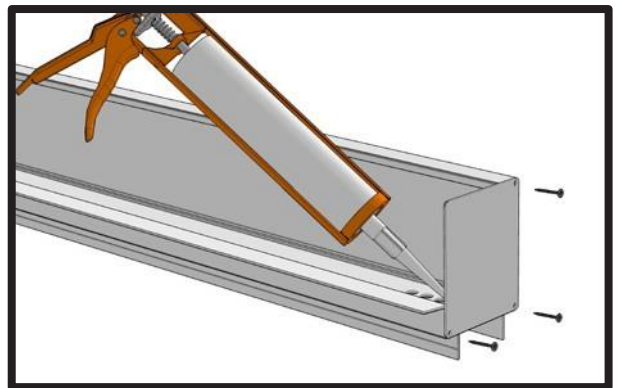

15. Place the gutter on top of the posts ensuring that it is directly opposite and in line with the wall plate.

- The posts will sit inside the two flanges on the bottom of the gutter beam section.



16. Drill 4 holes (two on each side flange) with a 5mm drill bit, evenly spaced, (20mm from each edge of the Post).

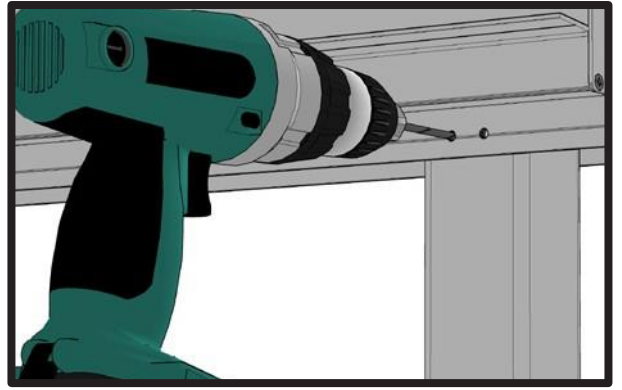

17. Secure posts to the gutter beam using the 4.8mm blind rivets. And silicone seal post if being used as downpipe.

- If space is tight due to obstructions, then the posts will have to be removed from the post connectors. The posts then fastened to the gutter beam and then the whole assembly of posts and gutter beam secured back onto the post connectors.

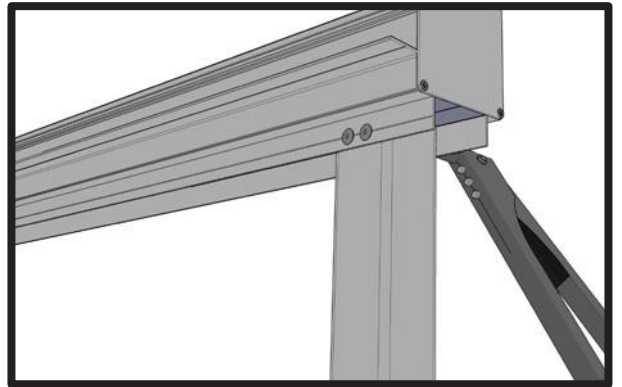

18. The bars will span from the wall plate, across to the front beam gutter. If the system is set to the maximum projection, then these will not need to be cut. If the bars do need to be cut, this should be done now before

- The base of the bar when in place should overhang into the gutter section 30mm when installed.

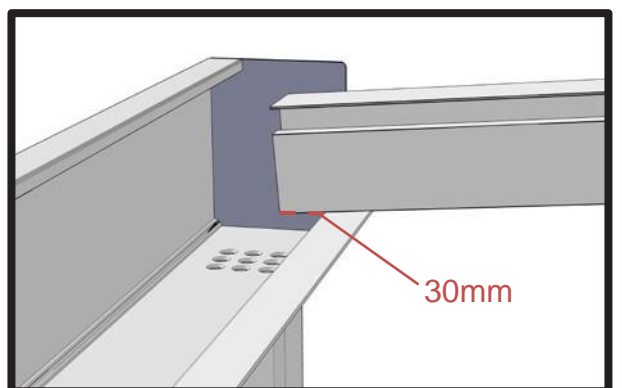

19. Once the bars are all the correct length, the bar endcaps should be installed on the end of each bar. This will then define the end of the bar that will be hanging into the gutter.

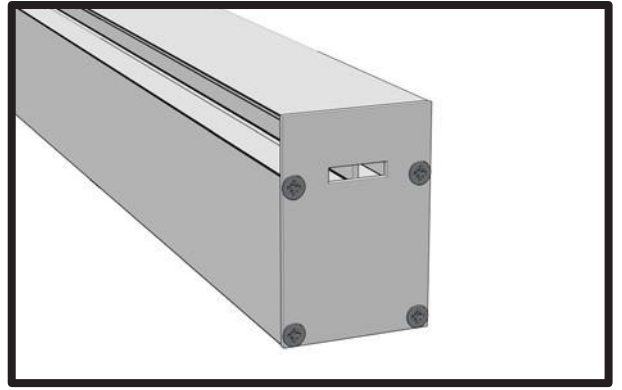

20. If the Bars are cut to length, then the sheets should be cut in length also to the same size using a fine tooth saw.

FOR SOLID SHEET INSTRUCTIONS SEE POINT 35

21. The protective film on the sheets should be peeled back approximately 50mm on all edges and on both sides.

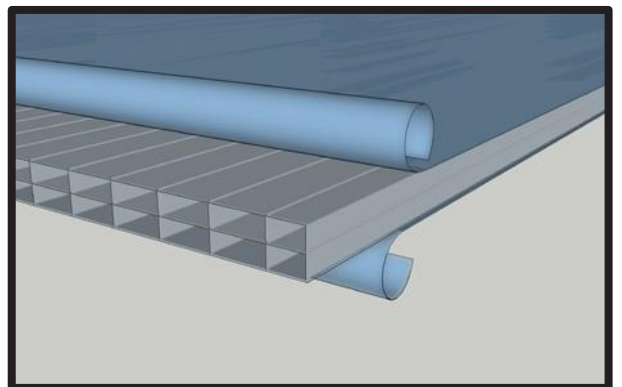

22. Ensuring the sheet is free from Dust moisture and any other debris the sheet tapes should be applied to the two sheet ends.

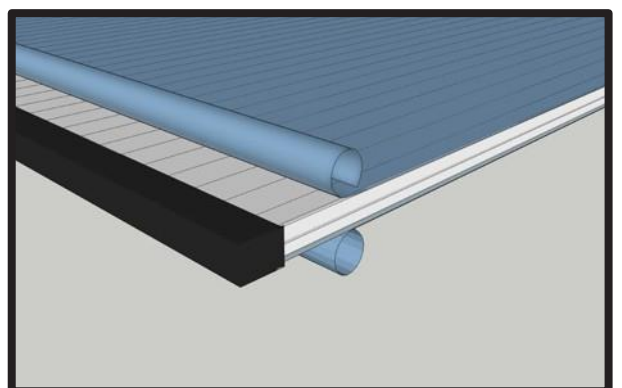

23. The sheet enclosures should be cut to 1M lengths and positioned over the tapes centrally.

- With the sheets being approx. 1050mm wide this leave approximately 25mm on each side uncovered.
- It is important that on the end of the sheet intended for the gutter that the drip section faces down as to not impede the flow of water off the sheet. At the end intended for the wall plate it is important to have the drip facing up to help act as a water buffer if there are hard driving winds.
- Polycarbonate multiwall sheets are UV treated, often this is only on one side. It is important that this side is the top surface. The sheet will tell you which this is, but general practice is that the cover film with the text on is the UV protected side.
- It is a good idea not to remove the cover films totally at this stage, because they will help protect the sheets from rub marks, and it is easy to forget which side should face up, and once the cover film is removed it is nearly impossible to tell.

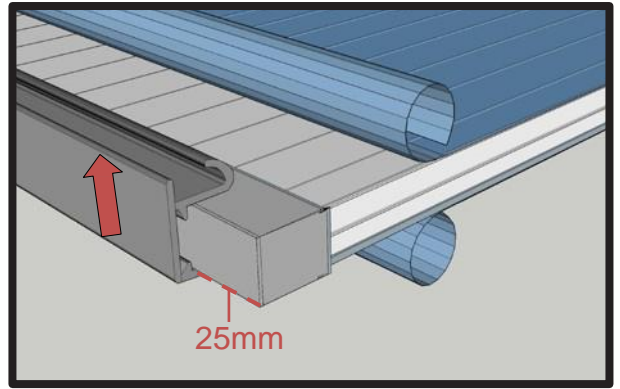

WALL PLATE END

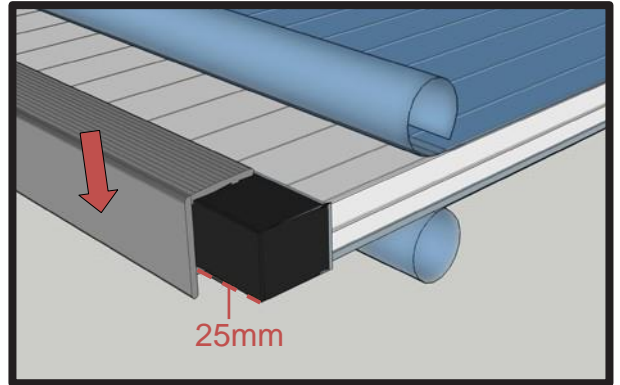

GUTTER END

24. The first bar should be positioned flush against the gutter beam endcap, and flush with the end of the wall plate also. The bar should overhang the gutter 30mm with the endcap at the gutter end.

- A handy way of ensuring the bar is in the correct position and help prevent it from moving when installing is to put a 60mm wide block of wood or offcut of post into the gutter. This will space the bar so that it overhangs correctly. But any such packing must be removed after the bar is secured.

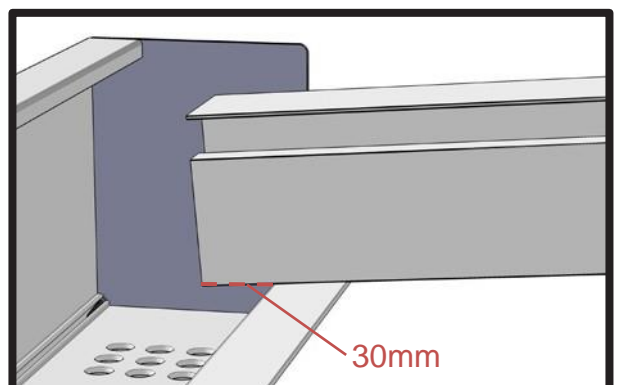
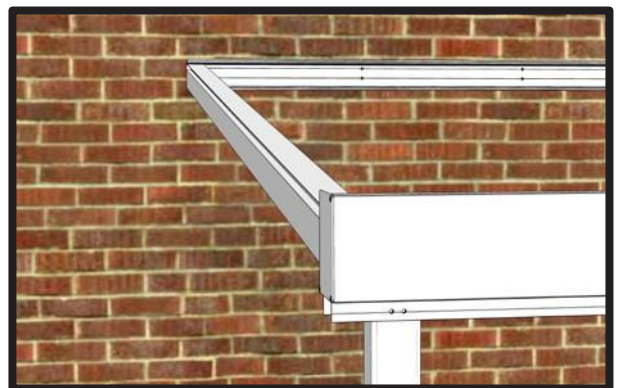

25. From underneath drill two 5mm holes through the underside of the wall and glazing bar (along the fixing groove line).

These should be 10mm from the two outer edges of the glazing bar to allow a strong fixing.



26. Fasten the wall plate and bars together using two 4.8mm x 12mm blind rivets through the fixing holes just created.

27. Repeat steps 25 & 26 but on the front beam not the wall plate.

28. Insert the polycarbonate sheet into the bar side, ensuring the sheet is the correctly prepared (step 23) and the correct way up. Ensure the sheet is fully retained in the bar and that the 1M sheet closures are up tight to the bar. This is important as the sheet closures will help ensure the bars are spaced correctly.

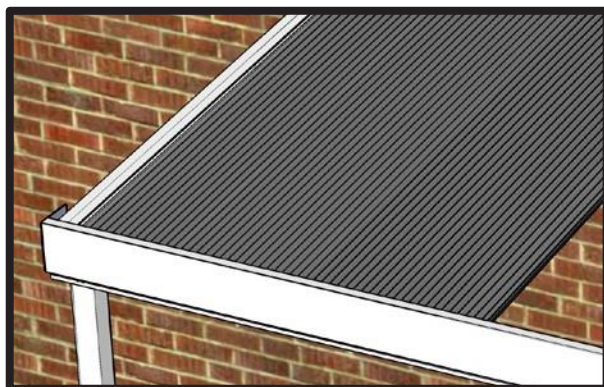

29. Insert a new bar onto the frame and engage the polycarbonate sheet so that the two long sides of the sheet are supported. These bars should now be spaced 1M apart (1050mm bar centers).

- Remember the endcap of the bar should be at the bottom (gutter) end of the roof with the bar overhanging into the gutter 30mm.



30. Repeat steps 25 to 27 on the new bar just added.

31. Run a small bead of appropriate silicone sealant along the joint of the sheet and the bar.

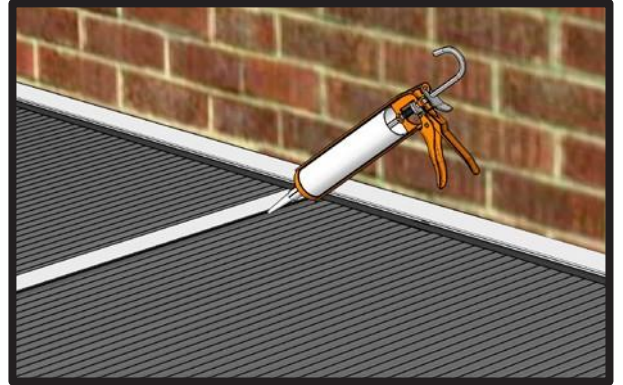

32. Repeat steps 28 to 31 until all the roof is glazed. The final bar should finish flush with the end of the wall plate and beam.

33. Screw the wall end plates in position, and seal with a small bead of silicone.

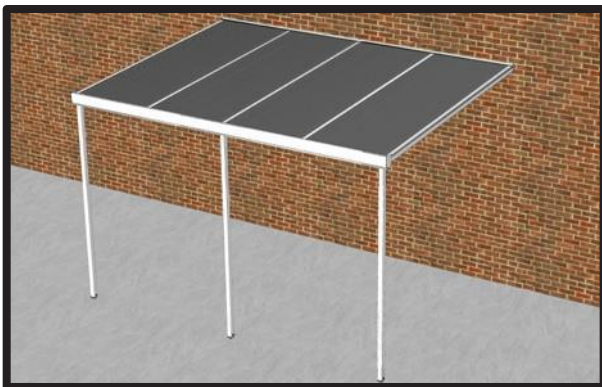
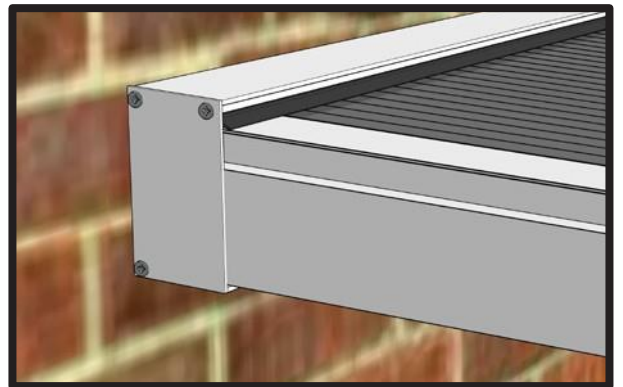

SHORTENED LENGTH CANOPIES

34. If the canopy is not going to be a standard length and needs shortening, then please remember that the dimensions listed here all need to be adjusted in proportion to the reduced canopy size. The sheets can be cut with a fine tooth saw and the aluminum with a hacksaw.

SOLID SHEET VERSION

35. Apply the 6mm rubber gasket to the sides of the sheet.

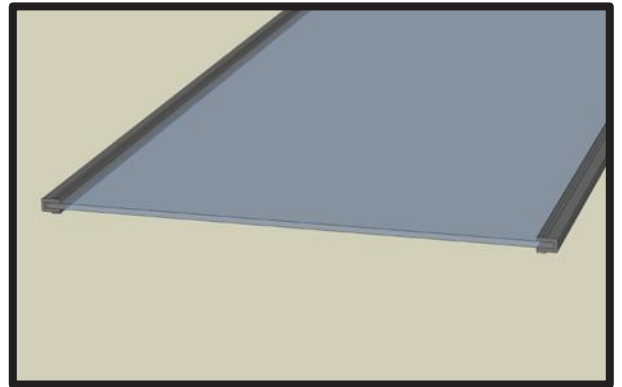
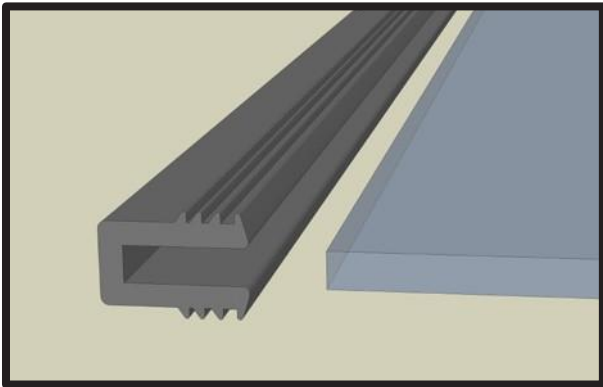

36. Cut the sheet enclosures to 560mm lengths and fit with the drip sections pointing down at the gutter end and pointing up at the wall-plate end.

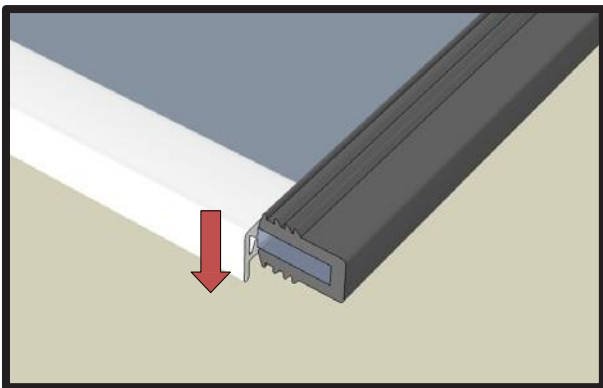

GUTTER END

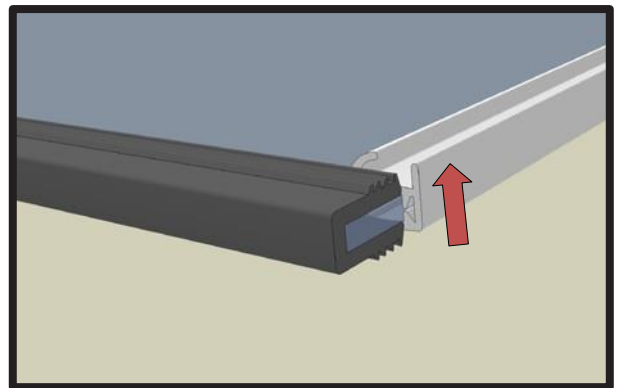

WALL PLATE END

37. Return to Point 24.

When ready, slide the sheets securely into the glazing bars

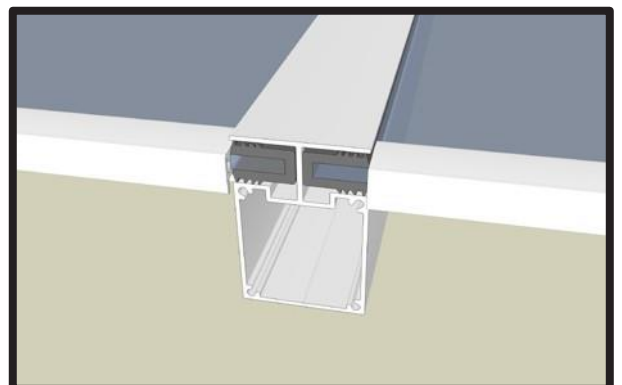

CUSTOM CONFIGURATIONS



CONSTRUCTING A LENGTH OF CONNECTED CANOPIES

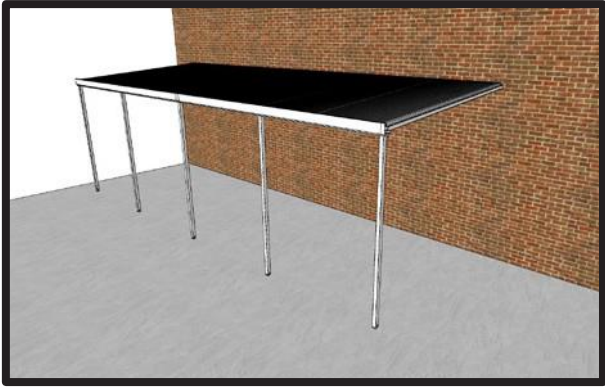

A1 Cut wall plates and gutters to size to make sure that the custom

- The wall plates and gutters located at each end need 25mm cut off from one end.
- Wall plates and gutters located in the middle of a run require a total of 50mm cut off from a single end.
- Retain the cut-offs as these will be used for bracing the wall plates and gutters together.

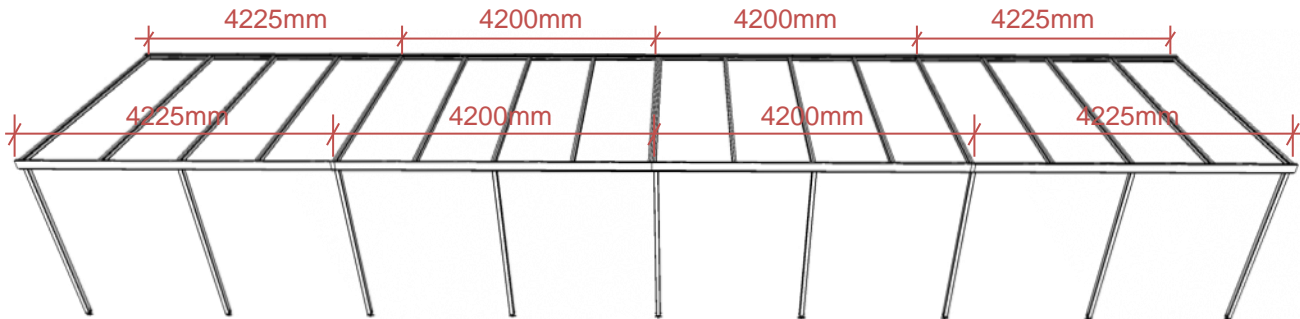
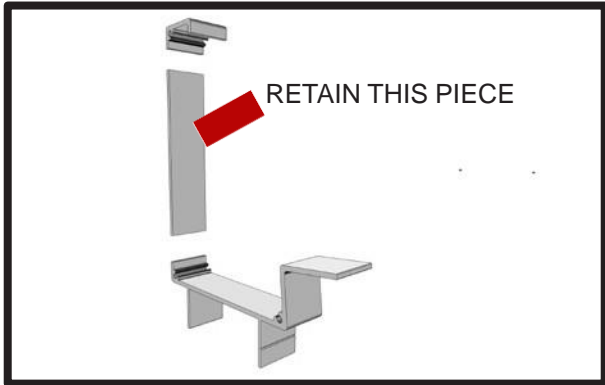
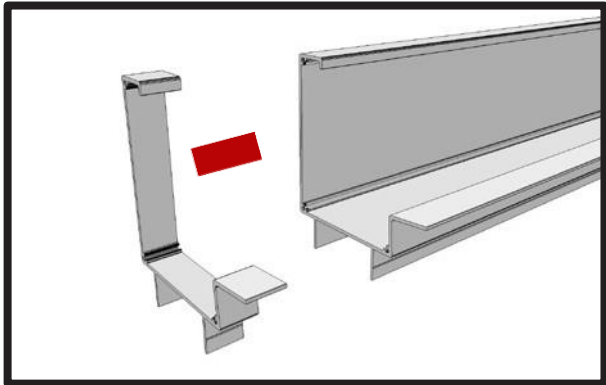
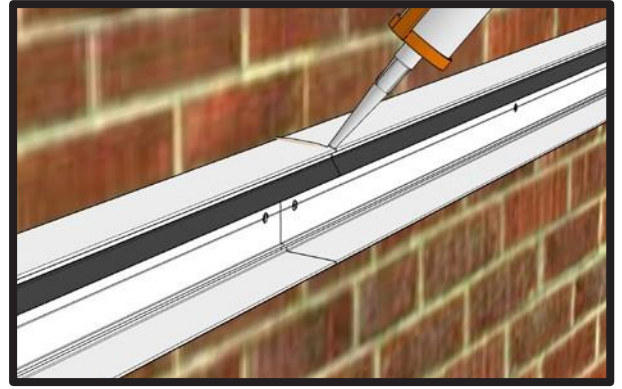
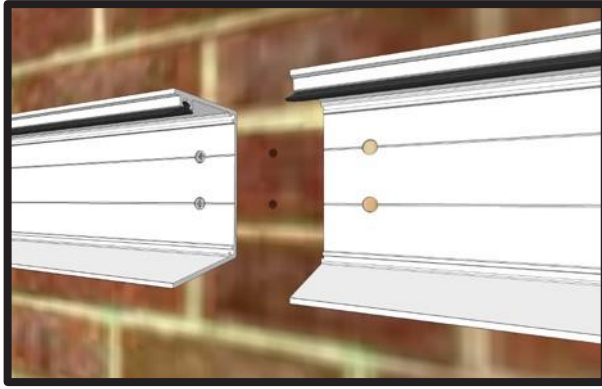

DIAGRAM ABOVE BASED ON 4250mm WALLPLATES AND GUTTER BEAMS



A2 Move the wall plates into position and seal with a bead of silicone



A3 Place the gutter beams together and position centrally over the post. Drill and fix with rivets. Use retained off-cut to brace

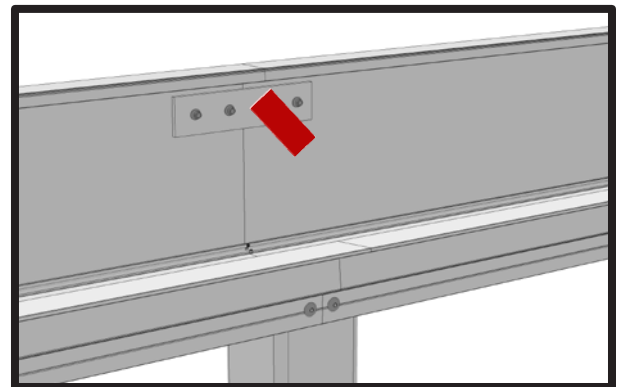
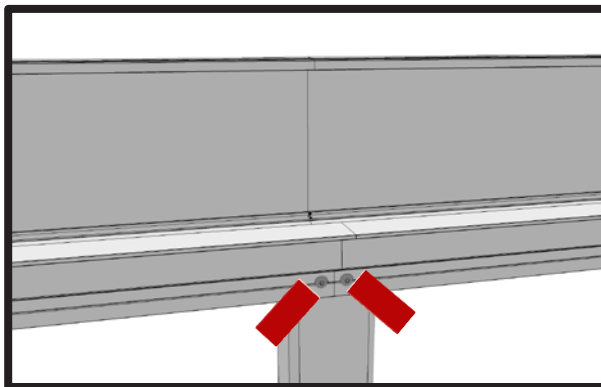

A4 Seal with a bead of silicone. In the final stages when adding the sheets and bars, make sure that the bars sit centrally over the posts and joints.

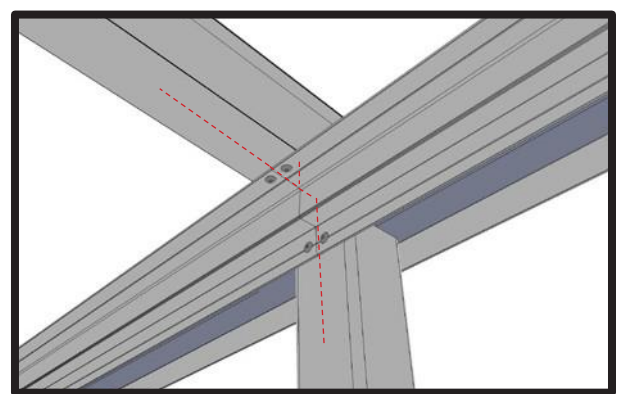
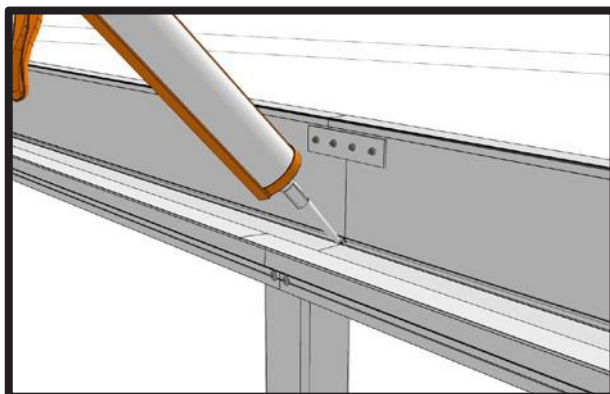

CONSTRUCTING CANOPY BETWEEN 2 WALLS

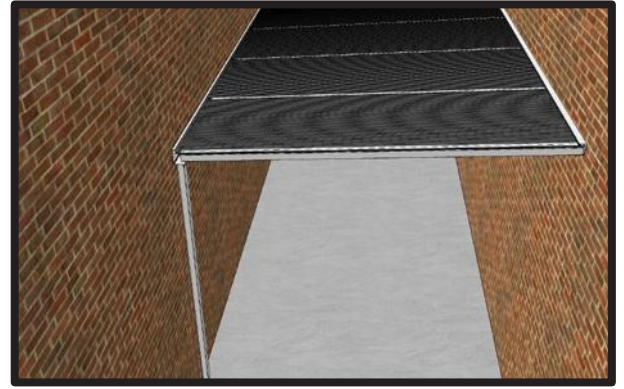
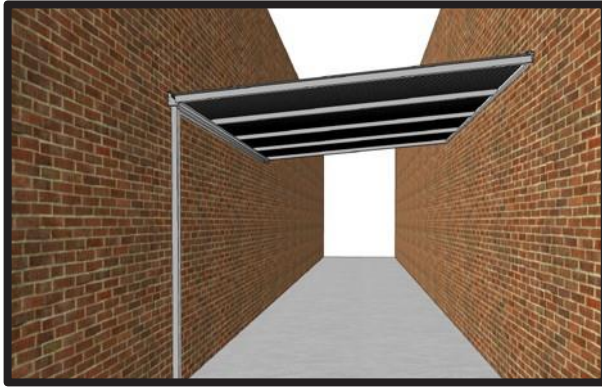

-
- D1** Follow item 2 of the main Sanctuary canopy instructions and apply to the gutter beam. Offer the gutter beam to the wall, fasten using through fixing frame anchors.

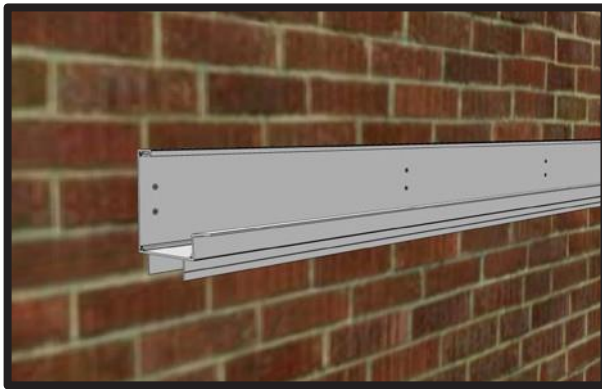

-
- D2** Decide where the gutter pipe should be. Follow items 12 and 13 of the main Sanctuary canopy instructions and apply to the gutter beam.

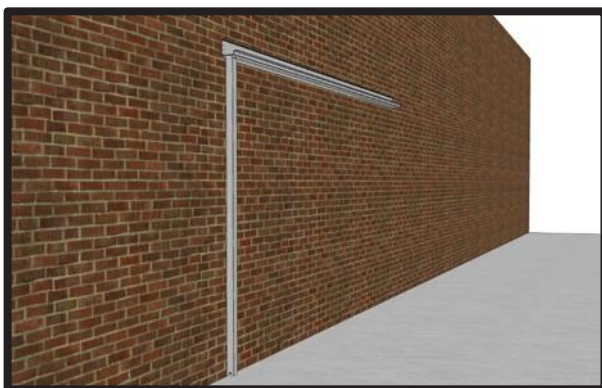

GILLINGHAM BRANCH

Courteney Road

Gillingham

ME8 0EZ

Tel: 01634 37 44 44

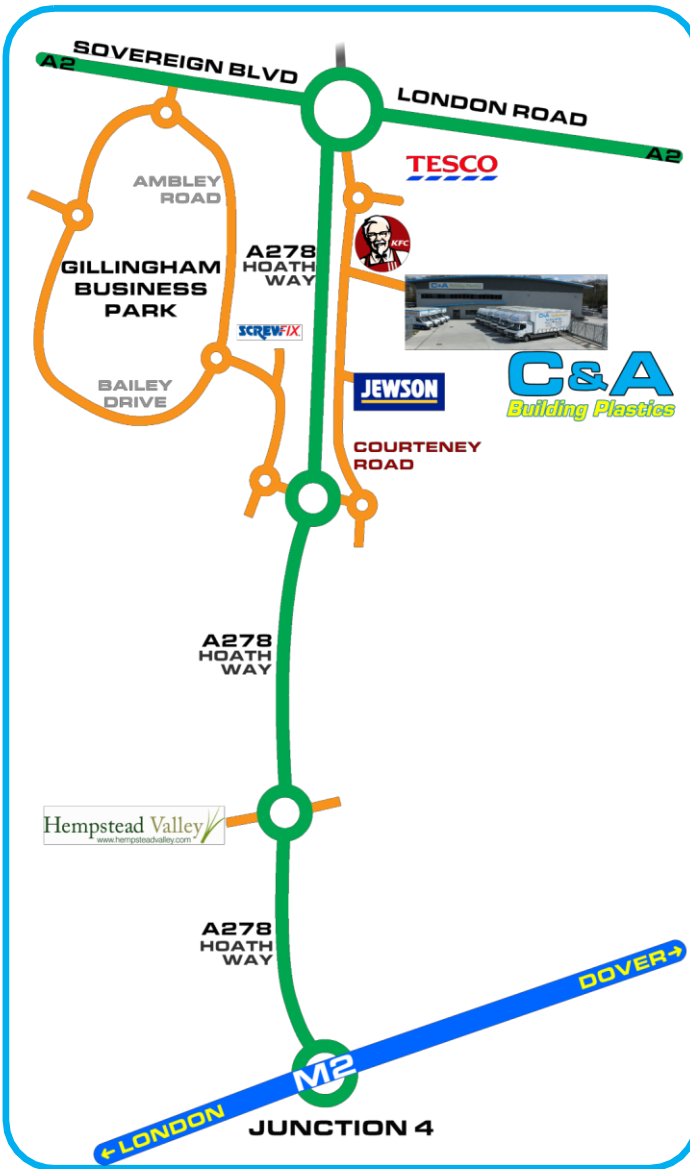

LONDON BRANCH

Bidder Street

Canning Town

E16 4ST

Tel: 0207 474 0474

